



## ASSEMBLY INSTRUCTION

### VANTRO LEATHER 2SEATER WITH SPEAKER CONSOLE

ITEM CODE 83816

Imported by Amart Furniture Pty Ltd, Qld, Brisbane Australia.

For any assistance with assembly or for missing parts please phone Amart Furniture, Customer Service Free call 1800 351 084

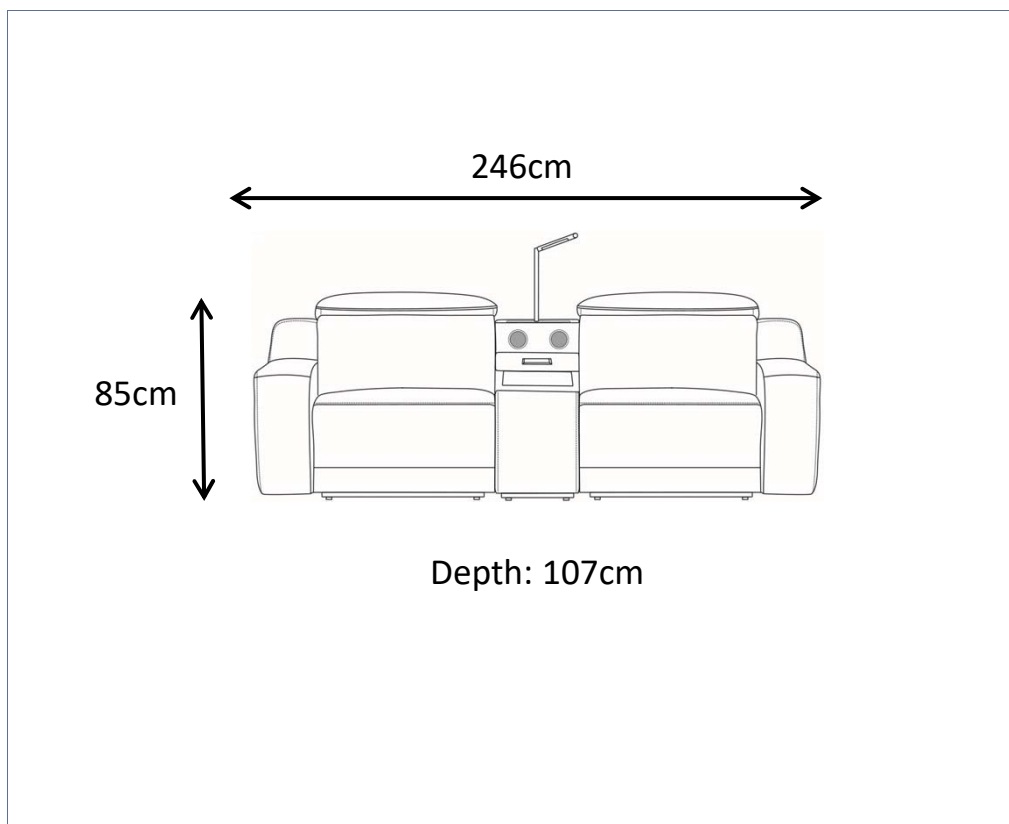



Imported by Amart Furniture Pty Ltd, Qld, Brisbane Australia.  
For any assistance with assembly or for missing parts please phone  
Amart Furniture, Customer Service Free call 1800 351 084

## PRE-ASSEMBLY PREPARATION

### Before you start:

1. Choose a clean, level, spacious assembly area. Avoid hard surfaces that may damage the product
2. Take care when lifting. Product should be assembled as near as possible to the point of use
3. Ensure that you have all required contents for complete assembly
4. Always read the assembly instructions carefully before beginning assembly.
5. Keep all hardware parts and packaging out of reach of small children.
6. Do not over tighten the screws and bolts as this may damage the threads



	
ALLOW 30MINUTES	PEOPLE REQUIRED
ADDITIONAL TOOLS REQUIRED	

### **WARNING**

- Do Not allow children to play on this mechanised furniture or operate the mechanism. Leg rest folds down on closing so that a child could possibly be injured. Always leave in an upright and closed position. Keep hands and feet clear of mechanism. Only the occupant should operate it.

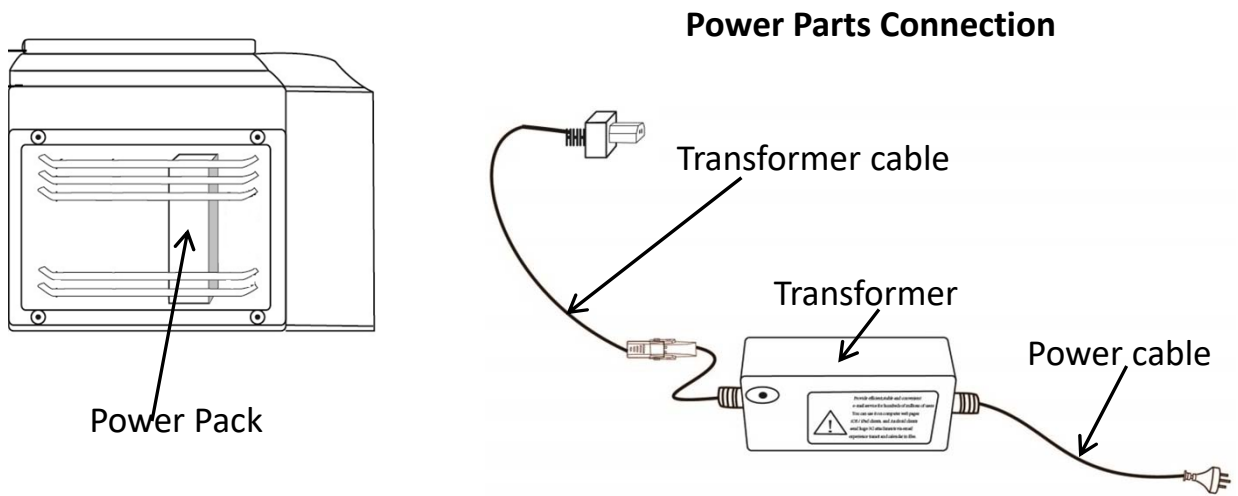

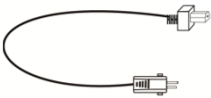
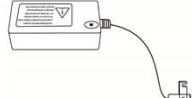
Step1: Locate and remove the recliner power pack (fixed to the mechanism) from underneath the one arm recliner seat.

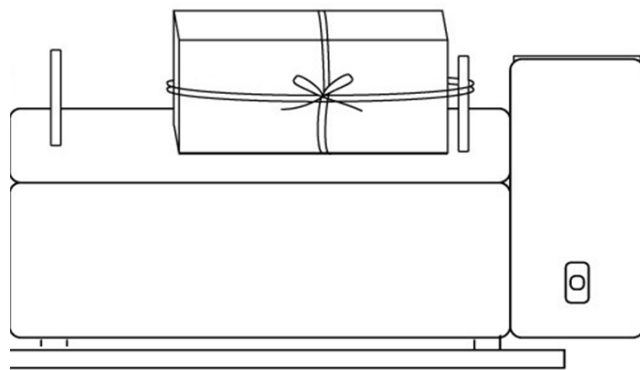

<p>Transformer cable</p>  <p>1pcs</p>	<p>Transformer</p>  <p>1pcs</p>	<p>Power cable</p>  <p>1pcs</p>
--	--	--

Step2: Remove the box tied to the mechanism post at the rear of the one arm recliner. This contains the wing and fittings.

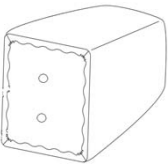
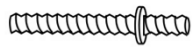

<p>Left wing</p>  <p>1pcs</p>	<p>Bolt</p>  <p>2pcs</p>	<p>Nut</p>  <p>2pcs</p>
--	---	--

Step3: Turn the wing on its side and screw the short end of the bolts provided into the base of the wing.

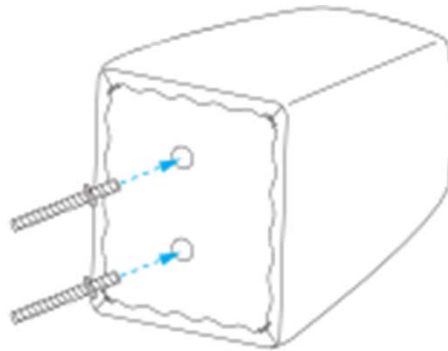

Step4: Carefully tilt the one arm recliner forward and lay flat so that you have access to the underside of the chair. Connect the wing to the one arm recliner base by placing the wing with bolts into the pre drilled holes at the rear of the recliner arm. Open the zipper pocket at the bottom of the recliner and secure the wing piece to the recliner arm by tightening nuts onto the bolts. Zip up pocket.

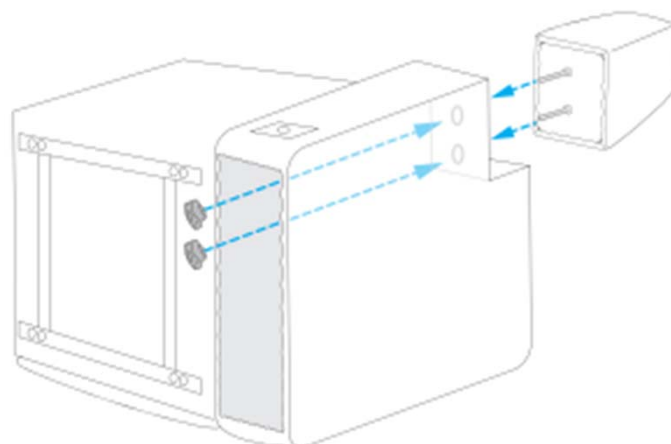



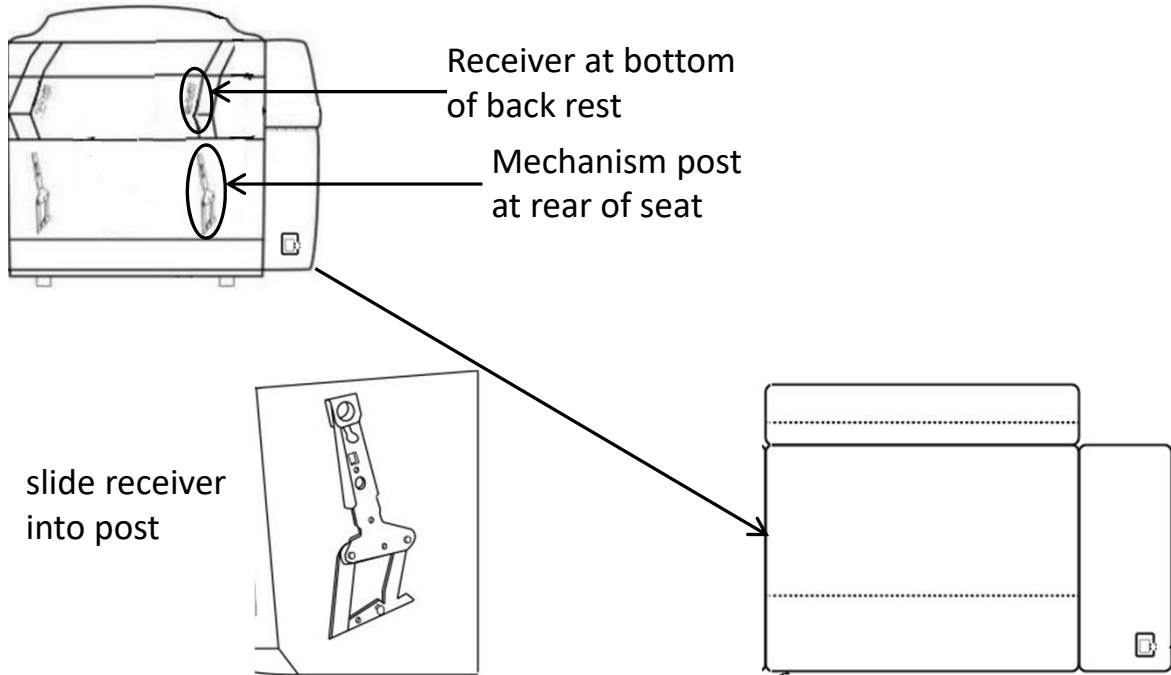

Step5: Connect the recliner backrest to the seat by sliding the backrest receivers into the steel mechanism posts at the rear of the seat. Press firmly and evenly down on both sides of the backrest to ensure this is fully locked into place.

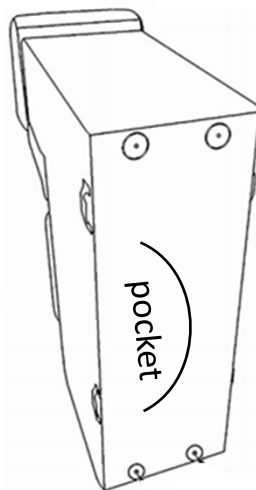

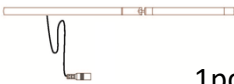
Step6: Locate and remove the power cord, reading light, light extension cord, ring cover and sofa legs from the zipper pocket in the bottom of the console.



<p>Power Cord</p>  <p>1pcs</p>	<p>Reading Light</p>  <p>1pcs</p>	<p>Light Extension Cord</p>  <p>1pcs</p>	<p>Sofa Leg</p>  <p>4pcs</p>	<p>Ring Cover</p>  <p>1pcs</p>
---	--	---	---	---

Step7: Secure the 4 x sofa legs provided onto each corner of the console by placing the feet in the pre-drilled holes and turning the feet in a clockwise direction to tighten.

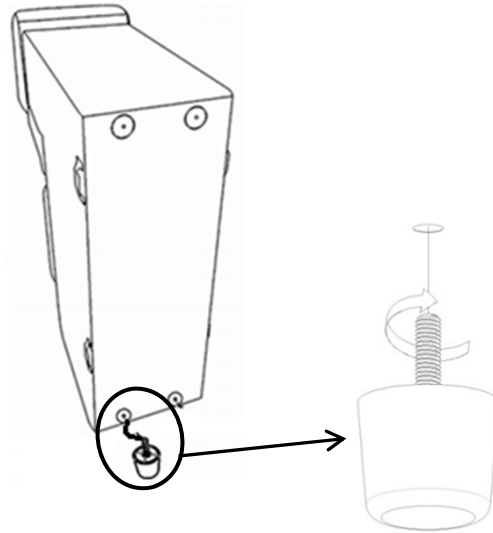

Step8: Return the console upright to fix the reading light at the top rear panel and then connect light extension cord with socket cord inside console.

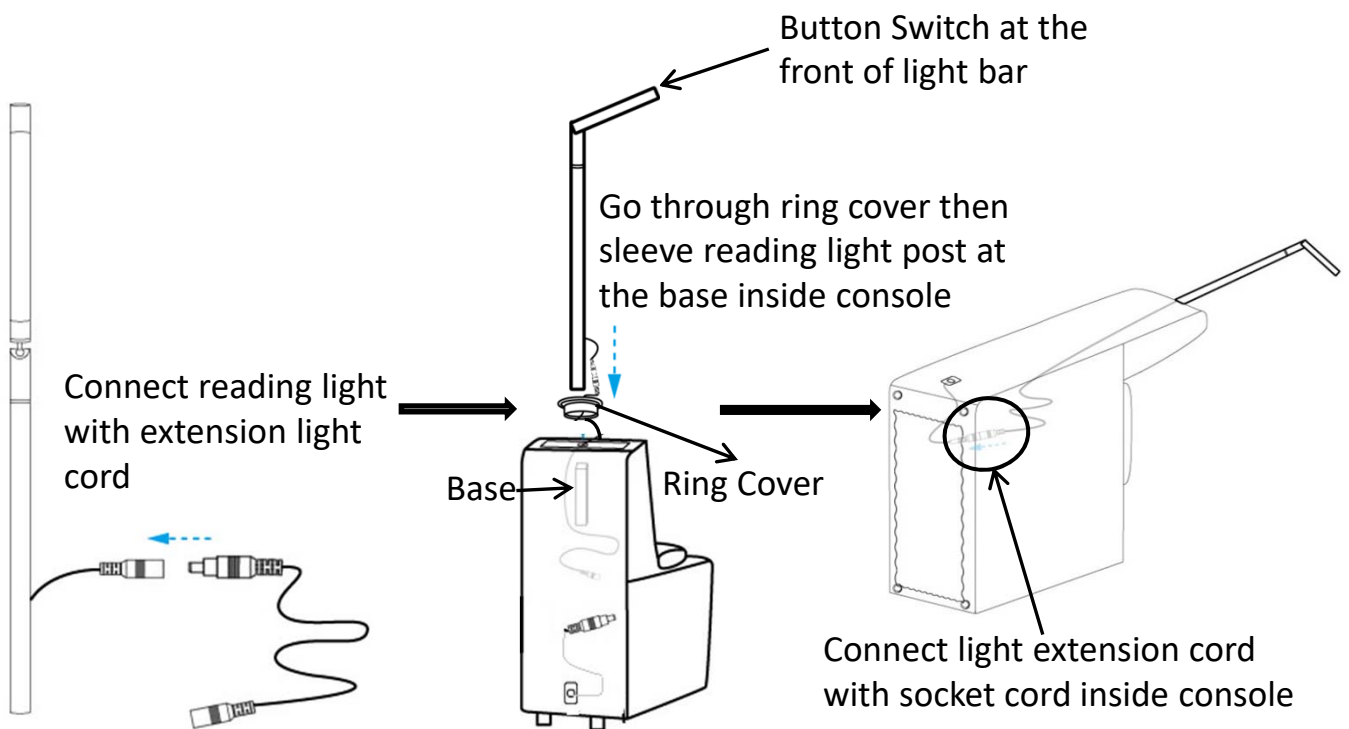

Step9: Repeat steps 1-5 for assembly of another recliner.

Step10: Connect all 3 pieces from right to left. Begin with the right hand facing piece, then console, then left hand facing piece. Slide clips together then press the front and rear sides to ensure the clips are connected all the way to the bottom.

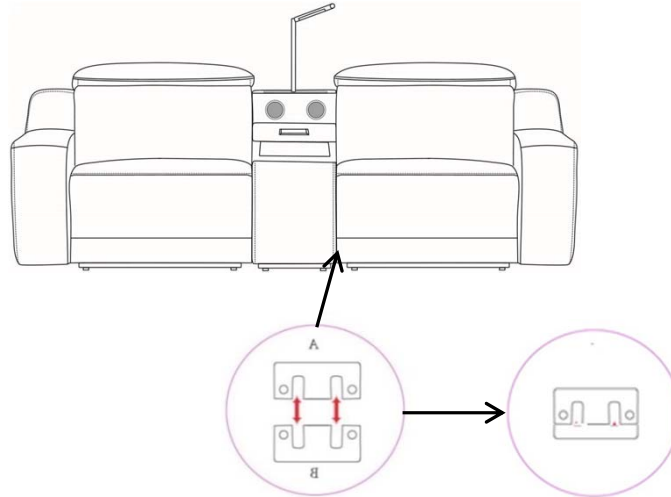

Step11: Plug power parts connection (refer to step 1) into socket at back panel of reclining seats, also plug power cord at back panel of console, then connect all of them into power source / wall.

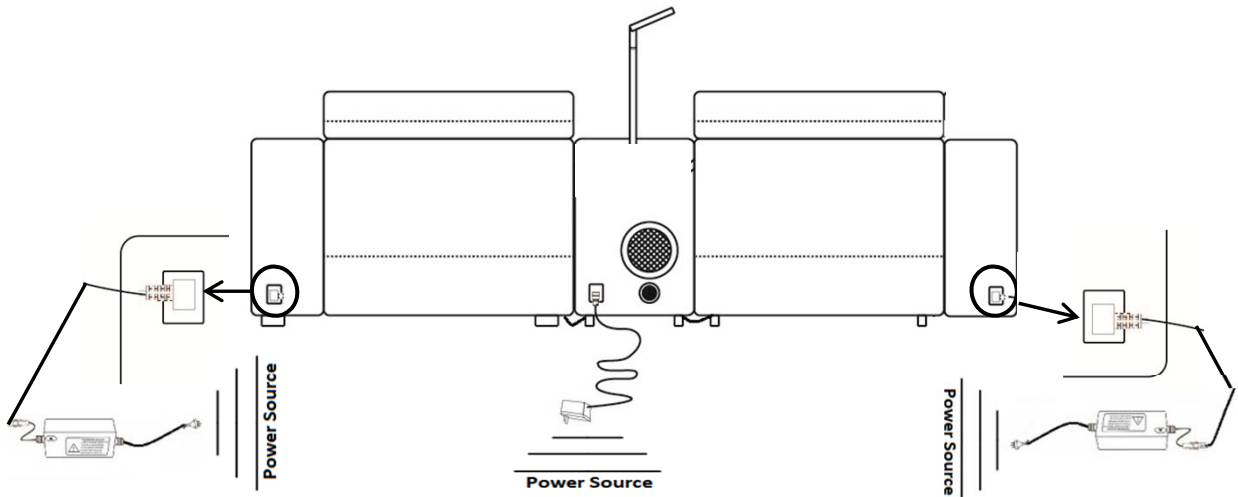

**IMPORTANT NOTE:** PLEASE ENSURE THAT ALL ELECTRICAL CORDS AND CABLES ARE CLEAR OF THE FRAME AND MECHANISM. FAILURE TO DO SO MAY SEVER YOUR POWER CORD RESULTING IN SERIOUS INJURY OR DEATH.

**SAFETY NOTE** WARNING! AVOID POTENTIAL EQUIPMENT DAMAGE OR ELECTRIC SHOCK! DO NOT PLACE THE TRANSFORMER UNDER OR WITHIN THE RECLINER STRUCTURE. DO NOT COVER THE TRANSFORMER. KEEP IT IN AN OPEN, WELLVENTILATED AREA FREE FROM FOREIGN MATERIAL / DEBRIS TO ENSURE PROPER OPERATION.

Step12: Your sofa should now recline. Refer to the below diagram on how to use the switch.

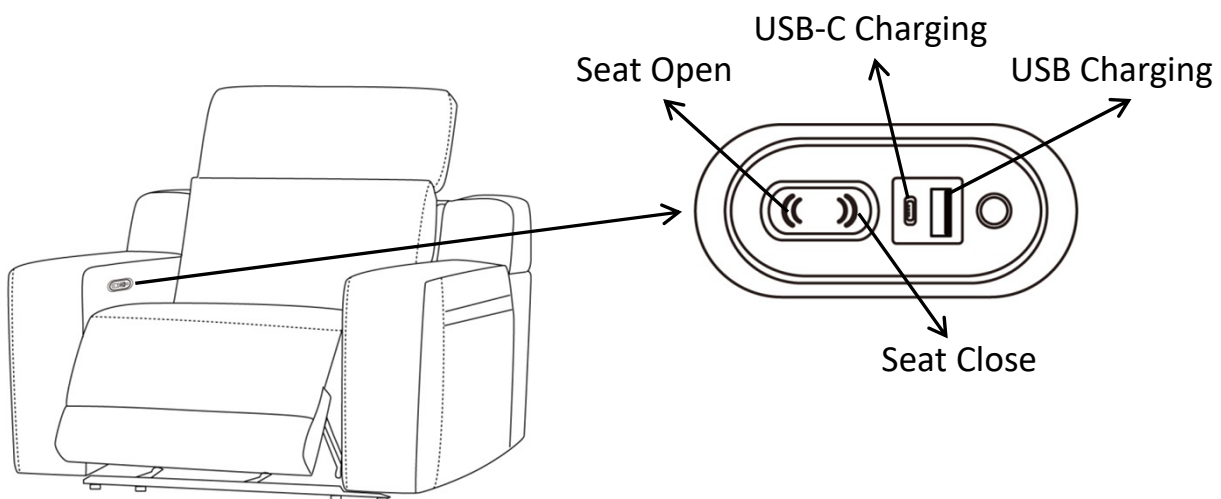

ASSEMBLY IS COMPLETE

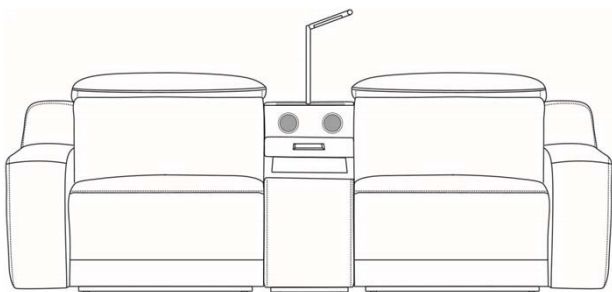

**READ THESE INSTRUCTIONS THOROUGHLY BEFORE USE:**

**DANGER:** TO REDUCE THE RISK OF ELECTRIC SHOCK:

Always unplug from electric outlet before cleaning.  
Always place transformer well away from recliner mechanism base.

**WARNING:** RISK OF INJURY

Keep children away from extended footrest and any moving parts.

**CAUTION:** Do not allow children to play on this electric recliner or operate the powered mechanism.

The leg rest folds when closing and could possibly cause injury to a child.  
Always leave the recliner in an upright and closed position when not in use.  
Keep hands and feet clear of mechanism. Only the occupant should operate it.  
Keep pets away from underside of recliner.

**POWER CORD SAFETY**

**WARNING:** Unplug and remove power cord from wall when not in use and store out of reach of children.  
Take care when moving recliner that wall and transformer cords are not under the base or they may get damaged.

**NEVER OPERATE ELECTRIC RECLINER IF IT HAS A DAMAGED CORD OR PLUG.**

**WARNING:** TO REDUCE RISK OF BURNS, FIRE, ELECTRIC SHOCK OR PERSONAL INJURY TO

PERSONS:

- Use only for its intended purpose.
- Never press or activate control switch if you are not seated in recliner.
- Only the occupant should activate the control switch.
- Never operate with more than one person occupying seat.
- Never sit or stand on the footrest.

## **READ THESE INSTRUCTIONS THOROUGHLY BEFORE USE:**

It is crucial to handle your reclining sofa with care. Following the intended usage guidelines will ensure safety and product longevity.

Recliners have a metal mechanism base, with moving parts to allow reclining functions. These components are flexible but can be easily bent or twisted if subjected to excessive weight, improper use, or excessive motion.

### **Safety**

Moving parts; particularly reclining mechanisms can be dangerous if used incorrectly:

- ALWAYS supervise children when they are around or on reclining furniture. Prevent them from operating the mechanism or playing on the recliner.
- Only the occupant should operate the recliner. When not in use, ensure it is returned to the lounges closed position.
- When closing the recliner-
- Always check underneath the mechanism to ensure that the footrests are folded down properly.
- Avoid placing hands and feet near the mechanism.
- Be mindful of children and pets, and the possibility of trapping items like clothing or blankets in the mechanism.

It is recommended that the closing motion be closed slowly.

### **General Care**

It is crucial to use recliners carefully and in accordance with their intended design to maintain their structural integrity. Misuse of the reclining mechanism can lead to bending or bowing. All Amart sofas have a weight capacity of 120kg per seat.

- Always ensure that footrests are fully closed before entering or exiting the seat. Using the seat with the footrest open can damage the structure and is not the intended usage.
- While reclined, the footrests are designed to support the weight of a single person's feet. Excessive weight, especially from pets and children, can overload the mechanism and cause twisting and bowing.
- Avoid leaning on the sides of the recliner at any time. Reclining seats are designed to be sat on in the middle as the centre of the cushion provides structural support. Leaning over the sides of the seat can twist the mechanism.
- Ensure that when you close the mechanism that equal weight is placed on the centre of the footrest panel. Do not close from the edges of the recliner's footrest. This causes stress on the mechanism and leads to a broken and bent mechanism. This is not a manufacturing fault but a result of improper use.

### Positioning your recliner

It is imperative that you ensure your recliner is positioned on a level surface to ensure its longevity.

Positioning your recliner on an unlevel or sloping surface can put additional strain on the internal components of your recliner.

The internal components of the recliner, such as the frame, levers, and hinges may experience increased stress if the recliner is constantly used on an uneven surface. Over time, this leads to premature wear and tear, affecting the recliner's durability, stability, and performance.

Additional issues that can impact electric recliners if positioned on an unlevel floor are as follows:

- 1. Motor strain** – The motor in an electric recliner is designed to operate under conditions where the load is evenly distributed. When the floor is not level, the motor works harder to adjust the recliner, leading to increased wear and tear over time.
- 2. Uneven Movement** – An electric recliner on an uneven floor may not operate smoothly or evenly. This can result in jerky movements, uneven reclining, or difficulty in adjusting the position, potentially causing discomfort for the user.

### Moving your recliner?

- Always ensure that the recliner is upright when transporting.
- Moving or transporting reclining sofas can be challenging due to their weight, which includes the mechanism and frame. Always ensure there are at least two people to lift the weight properly and avoid dragging or dropping the recliner as it can cause bending and bowing of the mechanism.
- Do not pull your sofa by the cushions and fabric as this will result in tears and rips.

# Product Care for Leather Items

When necessary brush or vacuum away dust and grit. Wipe over with a soft, clean, colourfast cloth

## **FOR SPOTS AND SPILLS:**

- Wipe excess liquid up immediately with an absorbent cloth or sponge

## **FOR OVERALL CLEANING:**

- We recommend cleaning every 3-4 months with leather cleaner followed by applications of leather protector
- Always follow directions on packs

## **NOTES:**

- Accumulation of perspiration and body oils on arm pads, headrests, etc. may damage your leather. These areas may require more frequent cleaning
- Leather is not recommended for users on frequent medication. Particularly heart, blood pressure, diabetes or chemotherapy medication. This medication can seep through the skin and when combined with perspiration, attacks the protective polyurethane coating of the leather
- Leather is a natural product and any stress may result in tears. Additionally when stretched the leather might not completely return to its original shape. Therefore when leather is used more intensively it may become loose over time
- If cushions are sewn to the frame, any pulling or tugging might result in a tear. Please avoid any leaning, sitting or reaching over the back/arms of the sofa
- To keep your cushions looking fluffy and new, use seating evenly
- Leather is not resistant to animals. Allowing pets on your leather is not recommended. Their claws and jaws may scratch the covers, which can lead to expensive repair. Their saliva is acidic and may also harm the leather finish

## **DO NOT:**

- Dry clean or machine wash
- Expose leather to direct sunlight, intensive heat, weather or soak unnecessarily. Always avoid excessive hard rubbing
- Use saddle soap, detergents, solvents, abrasives, unidentified leather cleaners, suede cleaners or any products containing silicon or solvents
- Use silicone based leather care products. These can damage the coating over time. Any leather care product with an oily or greasy feel should be avoided
- Expose leather to new clothing, cushions or throws as this may lead to dye transfer and permanent staining. Ensure these items are colourfast before placing them on the leather

# Speaker Control Panel Manual

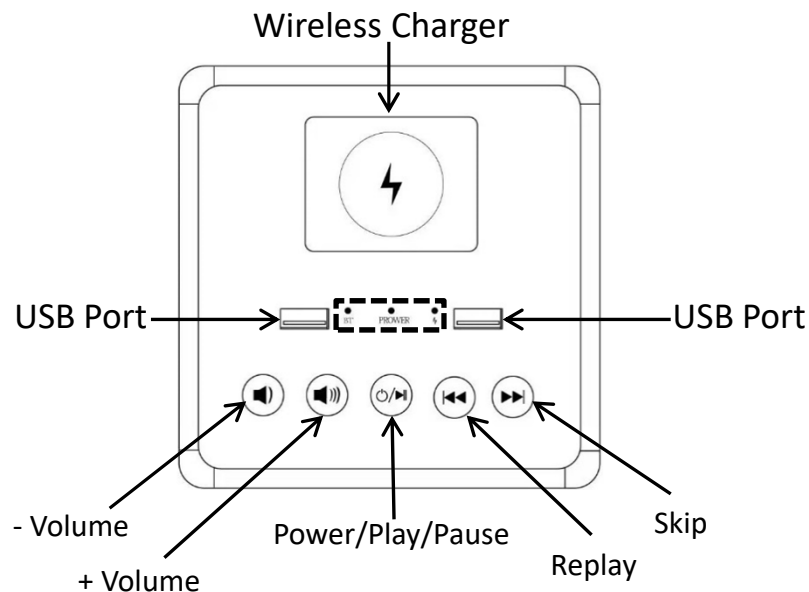

## Speaker Instruction:

### Bluetooth

- Bluetooth Name: Vantro
- How to Connect:
  - 1) Hold down the power button for 3 seconds.
  - 2) When the blue light (BT) starts flashing, connect your device. Ensure your device is within range.
  - 3) Once successfully connected the blue light (BT) will stay lit.

### Speaker Control Panel

- How to use:
  - 1) Hold the power button for 3 seconds to turn on/off.
  - 2) Press the “replay” and “skip” buttons to navigate.
  - 3) Press the “+ volume” and “- volume” buttons to control the sound.

### Wireless Charge:

- How to use:
  - 1) Place the device in the center of the red wireless charging panel. When the green light is on, wireless charge is successfully in operation.

### NOTE:

- To indicate that the console is connected to power, the red light (power) will stay lit .
- When the phone is paired and you receive a call or text, the sound will pause.
- The speakers will only work through Bluetooth connection, not USB or Wireless connection.

## Speaker Specifications

- Reproduction system
- Woofer.....  $\phi$ 104mm  
Magnet: 370g
- Tweeter.....  $\phi$ 78mm
- Nominal impedance.....  $6\Omega - 4\Omega - 4\Omega$
- Sensitivity.....  $92 \pm 3\text{dB}$   $82 \pm 3\text{dB}$
- Frequency response..... F0~10KHZ F0-12KHz
- Nominal power..... 20W
- Maximum music power..... 32W
- Grille material..... Steel net, ABS
- Weight (per speaker including accessory parts) .....1377g/198g
- Gross weight (2 speakers including packaging) .....1774g

## IMPORTANT INFORMATION

- DO NOT play the speakers for more than 6 hours continuously. In doing so may cause damage to your speakers.

## Wireless Charger Applications

**All cell phones with wireless charging function can be charged.  
The list below shows only some of the phones for your reference.**

Brand	Model Number	Brand	Model Number
Apple	iPhone 13 series	SAMSUNG	Note 20 series
	iPhone 12 series		S20 series
	iPhone SE2		S21 series
	iPhone 11 series		Galaxy Fold
	iPhone X series		SM-G9298
	iPhone 8 series		Galaxy S Lite
HUAWEI	P50 Pro 4G		Kelly(SM-W2018)
	P30 Pro		W2017(SM-W2017)
	Mate 40 series		W2016
	P40 Pro series		S10, S9, S8, S7, S6 series
	Mate 30 series		Note 10 series
	Mate 20 Pro&RS		Note 9, Note 8, Note 7
LG	Optimus series		Note FE, Note 5
	Spectrum 2		Black Berry
	LG Lucid series	PRIV	
	V50 series	Classic SQC100 series	
	V40 ThinQ	Z30 STA100	
	V35 series	Q20	